

VEGA

MODEL 2792512

RESOLVER TO ENCODER CONVERTER with HALL EFFECT SIMULATION FOR MOTOR CONTROL APPLICATIONS



*** APPLICATIONS ***

- Ideal For Closed Loop Positioning Systems
- Nuclear Applications
- Machine Tools
- Servo Motor Control
- Spindle Motor Control
- PLC Positioning Control
- Index/Rotary Tables
- Transfer Lines
- Positioning Systems
- Robotic Applications
- Dispensing Systems



RESOLVER TO DIGITAL INTERFACE

- Works with R11, R25, or most any Synchro/Resolver
- Incremental encoder output signals
- Fixed Excitation Frequency of 10 kHz
- Personality module supports 256, 512, 1024, 2048 lines of A-quad-B with Index and complements
- Personality module supports resolver transformation ratio's of 0.25 to 4.0
- Personality module supports Hall Cycles of 1,2,3, and 4 per resolver cycle

With the VEGA 2792 series of converter you can have both the ruggedness of a resolver and the digital simplicity of an encoder interface. The 2792 series can be used with almost any resolver. The INDEX/MARKER pulse (Channel Z) will occur once per transducer cycle at the zero degree position.

*** ADVANCED FEATURES ***

- Easy to Use and No Set Up Required
- Automatic Gain Adjust for transformation ratio's
- Fast Non-Phase Locked Loop Design (<50 uSec)
- Highly Accurate
- Tuned Filter for Noise Immunity
- A-Quad-B, Index and Complements
- TTL/Line Driver Outputs
- Quadrature encoder signals to 4 mHz
- Single +5 vDC Supply Operation
- Loss of Signal Detection
- Fault Signal Output
- Status LED's for Power, Signal HI, and Fault
- Makes resolvers as easy to use as an encoder
- Compact Connector Design

2792 SERIES SPECIFICATIONS

Excitation 2 Phase:	10 kHz
Resolver Input:	0.8 to 18 vpp
Power Requirements:	4.8-5.4 vDC @ 250 mA
Drive Capacity:	200 mA Peak
Mechanical:	1.485 x 4.58 x 0.85
Accuracy:	+/- 3 arc minutes typical

SIMULATED HALL EFFECT OUTPUTS

The 27925x2 Resolver to Digital Converter uses the resolver signals to produce three Hall type signals at TTL levels to duplicate the signals required by drives using Hall effect sensors to determine the shaft position for commutation purposes. This makes the 27925x2 IDEAL for retrofitting Drives for AC Servomotors requiring indicators of motor shaft position in order to properly commutate the winding power.

CONVERTER ACCURACY AND TRACKING RATE

The 2792 board was designed for high speed applications. The standard converter accuracy is +/- 3 arc minutes. The maximum tracking rate is a function of the excitation frequency and the quadrature counts. With a 10 kHz excitation and 4096 quadrature counts per cycle the maximum tracking rate would be 28,000 RPM. With 10.0 kHz excitation and 8192 quadrature counts the maximum tracking rate would be 14,000 RPM.

PRICING AND DELIVERY

Model	Description	Price	Delivery
2792512	Resolver to Digital w/Hall	\$750.00	In Stock

2792512 Rev. K

**VISIT US ON
THE WEB AT
VEGACNC.COM**

PEOPLE IN CONTROL OF MOTION

P1 RESOLVER CONNECTOR

PIN#	FUNCTION	COLOR
1	Ref+ (R1)	Red/Wht
2	Ref- (R2)	BLK/Wht
3	Cosine+ (S2)	Yellow
4	Cosine- (S4)	Blue
5	Sine+ (S1)	Red
6	Sine- (S3)	Black
7	Thermal IN	Org/Wht
8	Thermal OUT (GND)	Orange
9	Shield (Isolated)	SHLD
10	*PUPV Reset (+24 vDC)	
11	!Fault (0 vDC = Fault)	
12	Fault IN (+24 vDC)	

P3 Kinetix 6x00 CONNECTOR

PIN#	FUNCTION
1	Channel A+
2	Channel A-
3	Channel B+
4	Channel B-
5	Channel Z+
6	DC Ground
7	No Connect
8	Hall C+ (S3)
9	No Connect
10	Channel Z-
11	Thermal Fault (0 vDC = Fault)
12	Hall A+ (S1)
13	Hall B+ (S2)
14	+5 vDC
15	No Connect

FAULT OUTPUT

FAULT OUTPUT

The 2792 series will Tri-State the A-Quad-B signals during a Fault condition (HI or LO signal level). This interface will allow an immediate Fault sense by equipment with loss of signal detection. The 2792 series will also open the contacts of the solid state relay between P1-12 and P1-11 to indicate a fault has occurred. This solid state relay can drive a 600 mAmp load.

POWER UP POSITION VALID FAULT

The 2792512 performs a position validation check on power up.

The In Position fault will occur during power up if the 2792512 detects more than +/- 15 quadrature counts from the power down position of the resolver. The fault is latched into memory and will remain even after cycling the power. Applying 4-30 vDC to P1-10 is the only way to clear the fault.

The FLT LED will flash 3 times to indicate the board has detected the out of position condition.

LED STATUS INDICATORS

PWR = Power Status Indicator

FLT:

1 Flash = Low Signal

2 Flash = High Signal

3 Flash = PUPV Fault (Power Up Position Valid)

power up position detected +/- 15 Counts of Error

4 Flash = Low Signal Intermittent

5 Flash = High Signal Intermittent

HSG = High Signal Indicator

QUADRATURE OUTPUT

The VEGA 2792 series of converter boards use RS-422-A differential drivers to provide 40 mA into a 100 ohm differential load. These outputs are also TTL compatible.

The output latency is dependent on the excitation frequency. With a 10.0 kHz excitation the response will be less than 50 uSec.

Quadrature is provided via Channel A+, Channel A-, Channel B+ and Channel B-. A count is considered to occur whenever there is a transition in either the Channel A or Channel B output signals. The Channel Z (Index) occurs once per resolver cycle.

QUADRATURE OUTPUT FORMAT

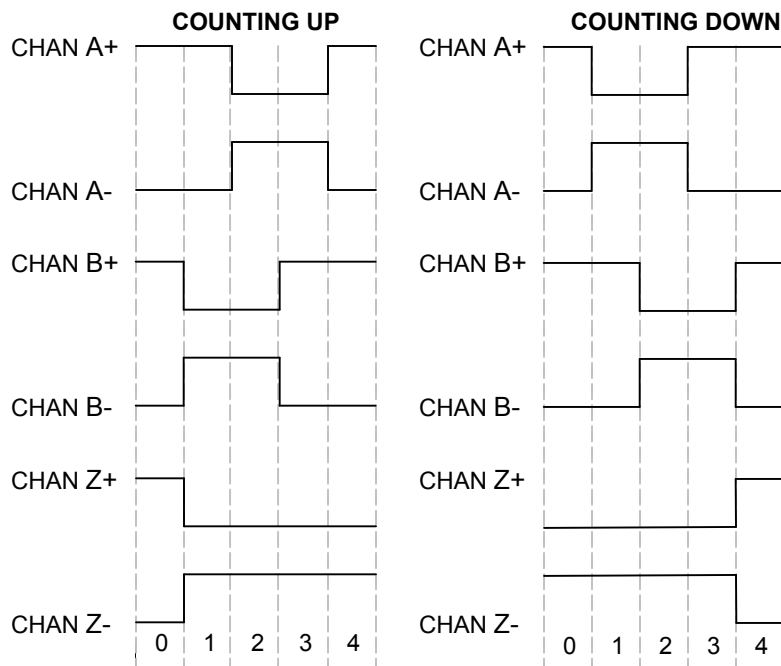

HALL EFFECT OUTPUT

Motors with Hall Effect Sensors and magnet are arranged to provide an output from the sensors to which the magnet is adjacent. The magnet may be adjacent to one sensor or between two sensors. When it is between two sensors, both sensors output a signal. This permits the detection circuitry to resolve the motor shaft position into 6 different sectors. The 2792 series produce signals that emulate the Hall Effect sensors for a seamless interface. The 2792 series supports up to 4 hall cycles per resolver cycle.

HALL EFFECT OUTPUT FORMAT

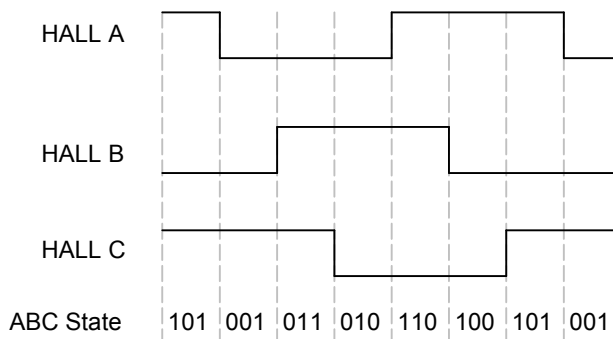

THEORY OF OPERATION

The 2792 series of converters generate precise Sine and Cosine excitations to excite the resolver stators (S1 & S3, S2 & S4). The resulting signal from the resolver rotor (R1 & R2) is a phase shifted excitation.

The phase shifted return signal is internally amplified by the base gain set by the personality module. It is then passed thru an active filter network to reduce noise. The advanced phase tracking algorithm tracks the phase shifted return and interpolates A-Quad-B pulses every 50 uSec based on the phase shifted return.

The return signal level is monitored for high signal level (HSG LED), and low signal level (FLT LED). During a low level detection or loss of power to the board the fault relay contacts will open (P1 Terminal 11 to P1 Terminal 12). The A-Quad-B outputs will be tri-stated after fault detection has occurred. The A-Quad-B will NOT be tri-stated in a power up position valid (PUPV) fault condition.

The Z channel (Marker Pulse) will occur once per resolver cycle (resolver pole pair) and will occur around 90 degrees from the sine excitation.

The power-up sequence for the 2792 is as follows:

1. The 2792 allows 50 mSec for the power to stabilize
2. The 2792 then starts the Sine and Cosine excitations with the sine being in sync with the command square wave
3. The excitation balance is restored from the "MAINTENANCE MODE" preset.
4. The 2792 will then initialize the A-Quad-B outputs with channel A and B active (high state) and the Z channel (index/marker) to inactive (low state).
5. The input gain is then adjusted to mid-range as described below. This process will take 150 mSec.
 - a. The input gain is set to the minimum level with the low level gain detection on (red FLT LED)
 - i. The 2792 will flag a "LOW LEVEL" fault if it is unable to adjust the gain out of the low level band.
 - b. The gain is increased until high level gain is detected (yellow HSG LED).
 - i. The 2792 will flag a "HI SIG" fault if it is unable to adjust the gain out of the high level band.
 - c. The gain is then set to the mid point of the low level detection and the high level detection.
6. 200 mSec after power on the 2792 will then set channel A and B inactive (low state) and set the Z channel (index/marker) active (high state).
7. The 2792 will then interpolate out quadrature counts to the nearest marker pulse. The interpolation rate during this period is fixed (1 mHz) and the time required for interpolation is based on the selected resolution.
8. After interpolating out the position to the nearest null, the 2792 will set the hall states based on the current motor shaft position to the resolver cycle.
9. The 2792512 then checks the stored position on power down to the current position and sets the PUPV fault and opens the contacts between P1-11 & P1-12.
10. The 2792 will then set the fault relay output based on any faults detected during the power-up sequence.
11. If low signal and high signal faults are not present, the 2792 will track the resolver position and output quadrature counts.

PERSONALITY MODULE

QUADRATURE COUNTS (J1-J2)

Jumpers J1-J2 selects 1024, 2048, 4096 or 8192 quadrature counts per resolver cycle

HALL CYCLES (J3-J4)

Jumpers J3-J4 select the number of hall cycles per resolver cycle as shown in the table below.

RESERVED (J5)

The J5 jumper is reserved on the 2792.

THERMAL TRIP

The 2792 series provides a low current interface to thermistors as well as thermal switches. The thermal trip point is set by R31 on the personality module for thermistors (Thermal switches will work with any value in R31).

GAIN RANGE

The 2792 series can interface with resolvers with transformation ratios from 0.25 to 4.0. The gain range is set by C21 on the personality module.

FUNCTION	J 1	J 2	J 3	J 4	J 5	Quadrature Counts
256 Lines	0	0				1024 Binary
512 Lines	1	0				2048 Binary
1024 Lines	0	1				4096 Binary
2048 Lines	1	1				8192 Binary
*1 Hall Cycle			0	0		
*2 Hall Cycle			1	0		
*3 Hall Cycle			0	1		
*4 Hall Cycle			1	1		
Default					1	
Maintenance					0	

* Hall Cycle per Resolver Cycle

POWER REQUIREMENTS

The 2792 series converters requires +5 vDC supply @ 250 mAmp for operation. The supplied power should have less than 50 mVolts of noise and drift.

CABLE SPECIFICATIONS

The 2792 series converters provide stable and precise sine and cosine excitations. These signals and the return signal are analog and proper routing and shielding techniques should be observed. Shielded twisted pair cables with drain wire should be used for the resolver interface

Recommended Cable

Shielded Twisted Pairs with Braid Shield and Drain Wire
Belden #8106 or equivalent

TEST POINTS

GND = Analog Ground
ST1 = Stage 1 Signal (3.8 vDC Peak to Peak)
SCL = Tracking Clock

INSTALLATION

- 1) Insure the personality module (see Personality Module) is installed on 2792
- 2) Install the 2792 board as described in the application drawing 2792512.

EXPLANATION OF POLES FOR DC MOTORS AND RESOLVERS

Commutation

Originally, dc motors used commutators and brushes to commutate the current in a wound rotor to provide torque in one direction or the other. Brushless dc motors use magnets on the rotor instead of windings, and require a means for indicating to the drive electronics, the orientation of the motor shaft in order for the electronics to commutate the current to the stator windings.

Early brushless dc motors frequently used auxiliary magnets mounted on the rotor and 3 Hall effect detectors on the stator to indicate the orientation of the rotor. The Hall effect detectors would indicate 6 distinct rotor positions to the drive electronics. Later motors frequently used integral resolvers to detect the rotor position, and the associated electronics would provide signals which emulated the output of the Hall detectors.

Poles

Brushless dc motors are frequently specified to have 2, 4, and sometimes 6 or more poles. The motors are invariably three phase. Current is commutated among the three windings to provide a magnetic field vector that rotates in one direction for clockwise and the other for counter-clockwise. The magnetic field vector will make one rotation per three phase electrical cycle. A 2 pole motor has a single magnet on the rotor with a north and a south pole, hence 2 poles or one pole pair. A 4 pole motor has 2 magnets, each with a north and a south pole, hence 4 poles or 2 pole pairs, and so on.

A 2 pole (single magnet) motor will make one rotor rotation per rotation of the magnetic field vector. That is, the rotor will make one revolution per motor electrical cycle

A 4 pole (two magnet) motor will require two electrical cycles to make one revolution, and a 6 pole (3 magnet) motor will require three electrical cycles per revolution.

A three phase Brushless motor will have 3 windings. A 2 pole motor will have the windings distributed to 3 stator poles spaced 120deg apart. A 4 pole motor will have its windings distributed to 6 stator poles spaced 60deg apart. A 6 pole motor will have its windings distributed to 9 stator poles spaced 40deg apart.

Hall effect emulation

Similarly, for appropriate commutation, the Hall effect emulation must provide one Hall cycle per motor electrical cycle. That is, a 2 pole motor will require one Hall cycle per revolution, a 4 pole motor, two Hall cycles per revolution, and a 6 pole motor, three Hall cycles per revolution.

Resolvers

Resolvers are sometimes similarly described as having 2, 4, or more poles. This simply means that the resolver makes respectively, one, two, or more, electrical cycles per rotor revolution.

The bottom line

Reduce everything to cycles. There will always be one Hall cycle per motor electrical cycle. There will always be an integral number of resolver cycles per shaft revolution. And there will always be an integral number of Hall cycles per resolver cycle.

2792 SERIES BOARD LAYOUT

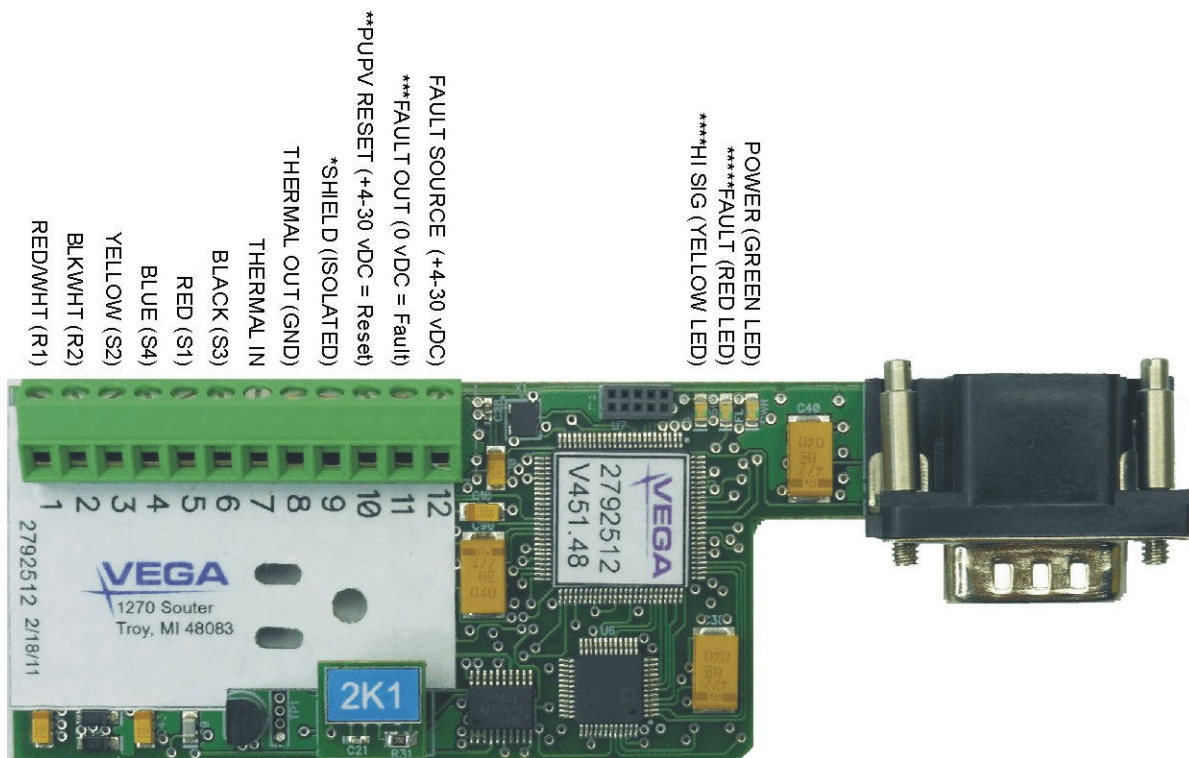

FAULT SOURCE (+4-30 VDC)
 ***FAULT OUT (0 VDC = Fault)
 **PUPV RESET (+4-30 VDC = Reset)
 *SHIELD (ISOLATED)
 THERMAL OUT (GND)
 THERMAL IN
 BLACK (S3)
 RED (S1)
 BLUE (S4)
 YELLOW (S2)
 BLKWHT (R2)
 REDWHT (R1)

POWER (GREEN LED)
 ****FAULT (RED LED)
 ****HI SIG (YELLOW LED)

PERSONALITY MODULE
 xKx
 NUMBER OF HALL CYCLES PER RESOLVER CYCLE
 NUMBER OF QUADRATURE COUNTS PER RESOLVER CYCLE
 (QUADRATURE COUNTS x 1024)

TROUBLE SHOOTING

SYMPTOM	CHECKS	SOLUTION
No Power LED	Check +5 vDC	+5 vDC Present → Board Failure – Replace board
Fault LED (1 Flash) Low Signal Detection	Check resolver cable	
	Check resolver coils resistance for open circuit and shorts to ground (S1 & S3, S2 & S4, R1 & R2)	Resistance values are less than 30 ohms – Check for shorts between “S1” and “S3” as well as ground. Check for shorts between “S2” and “S4” as well as ground. Check for shorts between “R1” and “R2” as well as ground.
	Check Sine and Cosine output excitations 3.6 vPP (P1-3 & P1-4) and (P1-5 & P1-6)	Missing excitation- Replace board
	Check “ST1” test point for 3.8 vPP	Missing reference signal- → Check cable for open/shorts on R1 & R2 → Replace resolver
Fault LED (2 Flash) High Signal Detection	Check for proper personality module gain setting	
	Check resolver cable	
	Check “ST1” test point for saturation (excitation is clipped)	Check for missing excitation on P1-3 & P1-4 and P1-5 & P1-6
Fault LED (3 Flash) Power Up Position Valid Fault (POPV Fault)	The 2792512 board has detected +/- 15 counts of position error from the power down stored position	The 2792512 requires an external reset from this fault. This fault is latched and requires +4-30 vDC applied to P1-10 to clear this fault.
Fault LED (4 Flash) Low Signal Detection (Intermittent)	See Low Signal Detection above	
Fault LED (5 Flash) High Signal Detection (Intermittent)	See High Signal Detection above	
Cyclic Error (erratic velocity)	Check “ST1” test point for Amplitude bounce of > 40 mVDC	Check resolver cables/ resolver
	Remove power and ohm between P1-3 & P1-4 note value. Ohm between P1-5 & P1-6 note value.	Resistance values are less than 30 ohms – Check for shorts between P1-3 & P1-4 as well as ground. Check for shorts between P1-5 & P1-6 as well as ground.
	With power on, check Sine and Cosine output excitations for 3.6 vPP on (P1-3 & P1-4) and (P1-5 & P1-6)	Missing excitation- Replace board
HSG LED (High Signal) Continuous	Check for proper personality module gain setting	Check ST1 for saturation- → See “Cyclic Error” → Install proper personality module
HSG LED (High Signal) Intermittent	Check “ST1” test point for 3.8 volts peak to peak	Follow procedures described in the Fault LED (Low Signal) Intermittent section
Feedback Polarity is Reversed	None	Swapping the Sine HI with the Sine LO wires will reverse the counting direction of the A-quadrant-B

APPLICATION INTERFACE

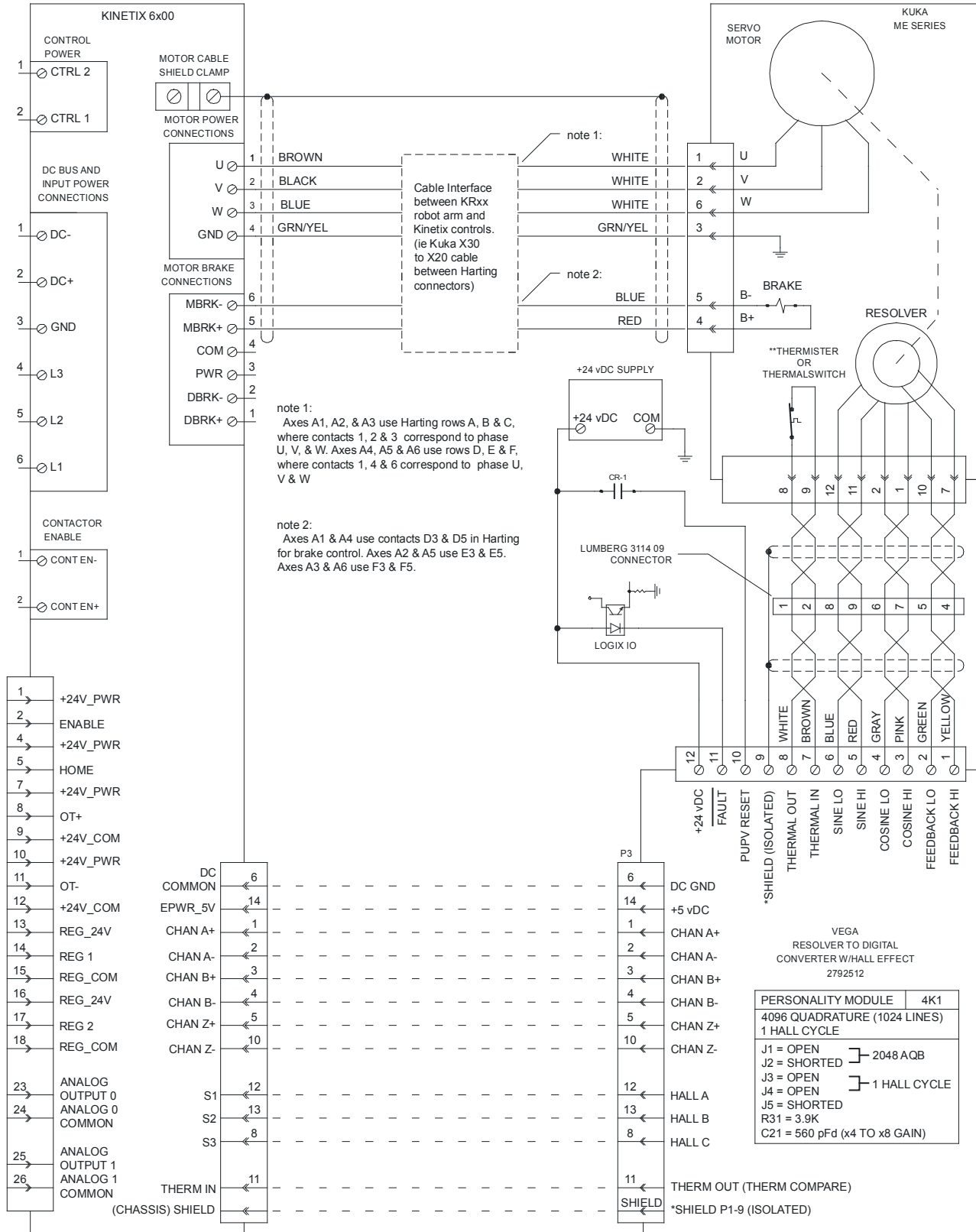

UNLESS OTHERWISE SPECIFIED TOLERANCES ON DIMENSIONS: 2 PLACES .010 3 PLACES .005 ANGLE .25 BREAK ALL SHARP EDGES .005 REMOVE ALL BURRS	VEGA CNC 1270 SOUTER BLVD. TROY, MI 48083	SCALE: N/A DRAWN: CODY CHECKED: CODY ENGINEER: WLH DATE: 08-20-11 NO: 2792 SHEET NO: 1 OF 1	NAME: 2792512 Kinetix 6x00 Kuka Robot SIZE: A DRAWING NUMBER: 2792512 CHANGE:
THIS DOCUMENT CONTAINS PROPRIETARY INFORMATION AND SUCH INFORMATION MAY NOT BE DISCLOSED TO OTHERS FOR ANY PURPOSE OR USED FOR MANUFACTURING PURPOSES WITHOUT WRITTEN PERMISSION FROM INNOVATIVE SUPPORT SERVICES INC.			